



Cambridge International Examinations
Cambridge International General Certificate of Secondary Education

CANDIDATE
NAME

--

CENTRE
NUMBER

--	--	--	--	--

CANDIDATE
NUMBER

--	--	--	--



COMPUTER SCIENCE

0478/22

Paper 2 Problem-solving and Programming

February/March 2017

1 hour 45 minutes

Candidates answer on the Question Paper.

No Additional Materials are required.

No calculators allowed.

READ THESE INSTRUCTIONS FIRST

Write your Centre number, candidate number and name in the spaces at the top of this page.

Write in dark blue or black pen.

You may use an HB pencil for any diagrams, graphs or rough working.

Do not use staples, paper clips, glue or correction fluid.

DO NOT WRITE IN ANY BARCODES.

Answer **all** questions.

DO NOT ATTEMPT TASKS 1, 2 AND 3 in the pre-release material; these are for information only.

You are advised to spend no more than **40 minutes** on **Section A** (Question 1).

No marks will be awarded for using brand names of software packages or hardware.

At the end of the examination, fasten all your work securely together.

The number of marks is given in brackets [] at the end of each question or part question.

The maximum number of marks is 50.

The syllabus is approved for use in England, Wales and Northern Ireland as a Cambridge International Level 1/Level 2 Certificate.

This document consists of **10** printed pages and **2** blank pages.

Section A

You are advised to spend no longer than 40 minutes answering this section.

Here is a copy of the pre-release material.

DO NOT attempt Tasks 1, 2 and 3 now.

Use the pre-release material and your experience from attempting the tasks before the examination to answer Question 1.

Pre-release material

An experiment has taken place which measures the reaction speeds of students. Each student is aged from 12 to 16, and belongs to a school house (Saturn or Mars). A program is required to store the age, school house and reaction time of each student in the school. There are 650 students in the school. The program should be able to output the reaction times of different student groups.

Write and test a program for the school.

- Your program must include appropriate prompts for the entry of data.
- Error messages and other output need to be set out clearly.
- All variables, constants and other identifiers must have meaningful names.

You will need to complete these **three** tasks. Each task must be fully tested.

TASK 1 – Set up arrays and store records

Set up one-dimensional arrays for the whole school to store the following data:

- The age of each student in whole years
- The school house of each student
- The reaction time of each student

Input and store the records for an **appropriate sample** of students. Inputs must be validated on entry and any invalid inputs rejected.

TASK 2 – Output school house based statistics

Using your sample, calculate and output the average reaction times for students in Saturn and students in Mars.

TASK 3 – Output statistics based on user input

Extend your program to prompt users to input a specific age and school house. Using only records that match the criteria input, the program should identify, calculate and output:

- The average reaction time
- The slowest reaction time

The output should include a suitable message for each of the reaction times identified.

Section B

2 Read this section of code that inputs the ages of people entering an event. The input sequence is ended by inputting a negative value for age. The code outputs the number of people at the event over the age of 18.

```
01 Num18 = 0
02 INPUT Age
03 WHILE Age >= 0 DO
04     IF Age >= 18 THEN
05         Num18 = Num18 + Age
06     ENDIF
07 ENDWHILE
08 PRINT Num18 - Age
```

There are four errors in this code.

Locate these errors and suggest code correction to remove each error.

Error 1

Correction.....

.....

Error 2

Correction.....

.....

Error 3

Correction.....

.....

Error 4

Correction.....

.....

[4]

3 There is a program that stores the following data:

- EmployeeID, an employee ID which must be two letters followed by 4 numbers, e.g. TY4587
- Manager, whether the employee is a manager or not
- AnnualHoliday, number of whole days' annual holiday
- PayGrade, the employee's pay grade which must be a single letter A–F

Complete the following table to identify:

- The most appropriate data type for each variable
- An appropriate validation check for each variable. You must use a different validation check for each variable.

Variable	Data type	Appropriate validation check
EmployeeID		
Manager		
AnnualHoliday		
PayGrade		

[8]

4 Study the flowchart.

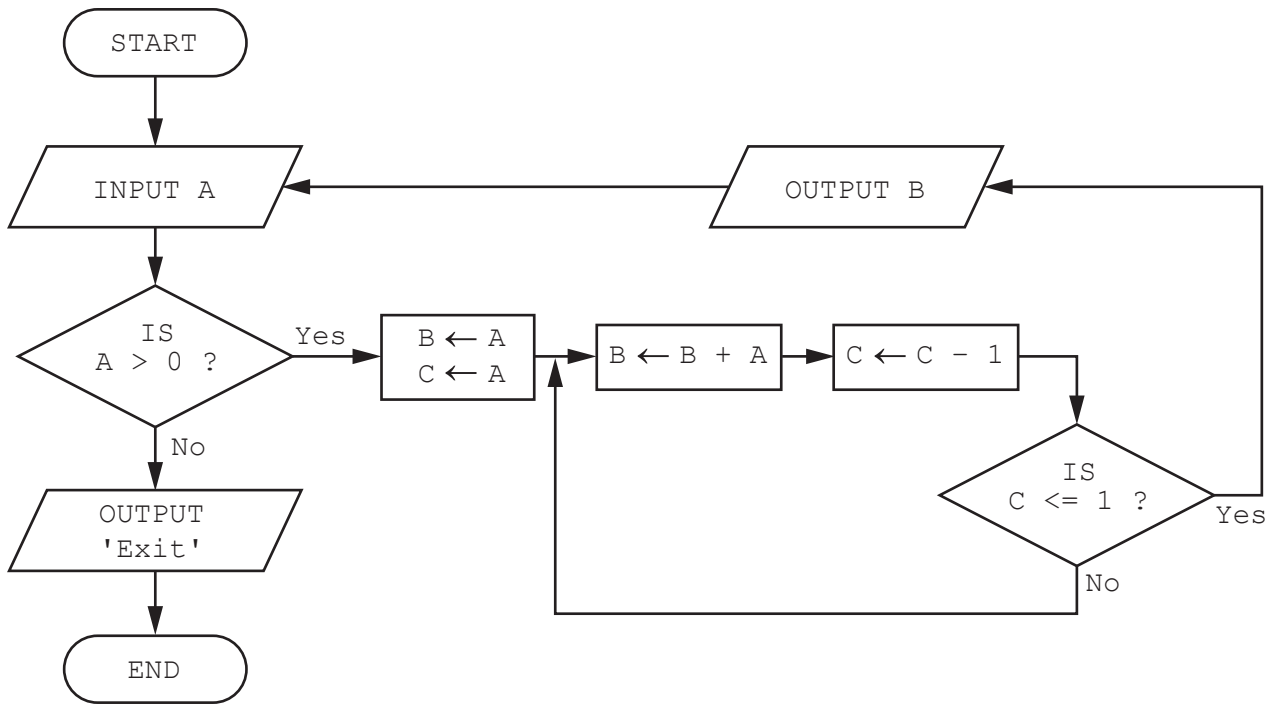

Complete the trace table for the input values 4, 3, -1:

A	B	C	OUTPUT

[4]

- 6 A database table, DEVICE, has been set up to record the electronic equipment used in a small business.

Device ID	Device Type	User	Purchase Date	Purchase Price (\$)	Portable
3	Desktop	Alan Swales	14/02/2017	1350.00	N
4	Laptop	Chantel Law	01/02/2016	1460.00	Y
5	Tablet	Abdula Saud	31/12/2016	1000.00	Y
6	Desktop	Abdula Saud	14/03/2017	1000.00	N
7	Laptop	Alan Swales	15/03/2016	1700.00	Y
8	Tablet	Taona Jaji	16/12/2016	470.00	Y

- (a) The query-by-example grid below selects certain records.

Field:	User	Portable	Purchase Price (\$)
Table:	DEVICE	DEVICE	DEVICE
Sort:	Ascending		
Show:	<input checked="" type="checkbox"/>	<input type="checkbox"/>	<input type="checkbox"/>
Criteria:		Y	>1000
or:			

Show what would be the output from the query-by-example.

.....

.....

.....[2]

- (b) Complete the query-by-example grid below to select all Desktop devices that were either purchased before 31/12/2016 or cost under \$1000. Only show the Device ID and Device Type.

Field:					
Table:					
Sort:					
Show:	<input type="checkbox"/>	<input type="checkbox"/>	<input type="checkbox"/>	<input type="checkbox"/>	<input type="checkbox"/>
Criteria:					
or:					

[4]

BLANK PAGE

Permission to reproduce items where third-party owned material protected by copyright is included has been sought and cleared where possible. Every reasonable effort has been made by the publisher (UCLES) to trace copyright holders, but if any items requiring clearance have unwittingly been included, the publisher will be pleased to make amends at the earliest possible opportunity.

To avoid the issue of disclosure of answer-related information to candidates, all copyright acknowledgements are reproduced online in the Cambridge International Examinations Copyright Acknowledgements Booklet. This is produced for each series of examinations and is freely available to download at www.cie.org.uk after the live examination series.

Cambridge International Examinations is part of the Cambridge Assessment Group. Cambridge Assessment is the brand name of University of Cambridge Local Examinations Syndicate (UCLES), which is itself a department of the University of Cambridge.